

# MODEL: A680 ASSEMBLY INSTRUCTIONS

10/24/2018

1. AFTER OPENING CARTON, REMOVE INNER CARTON AND INSTALL CASTERS TO CABINET AS SHOWN IN FIGURE #1. GENTLY ROLL CABINET OVER AND SET UP ON CASTERS.

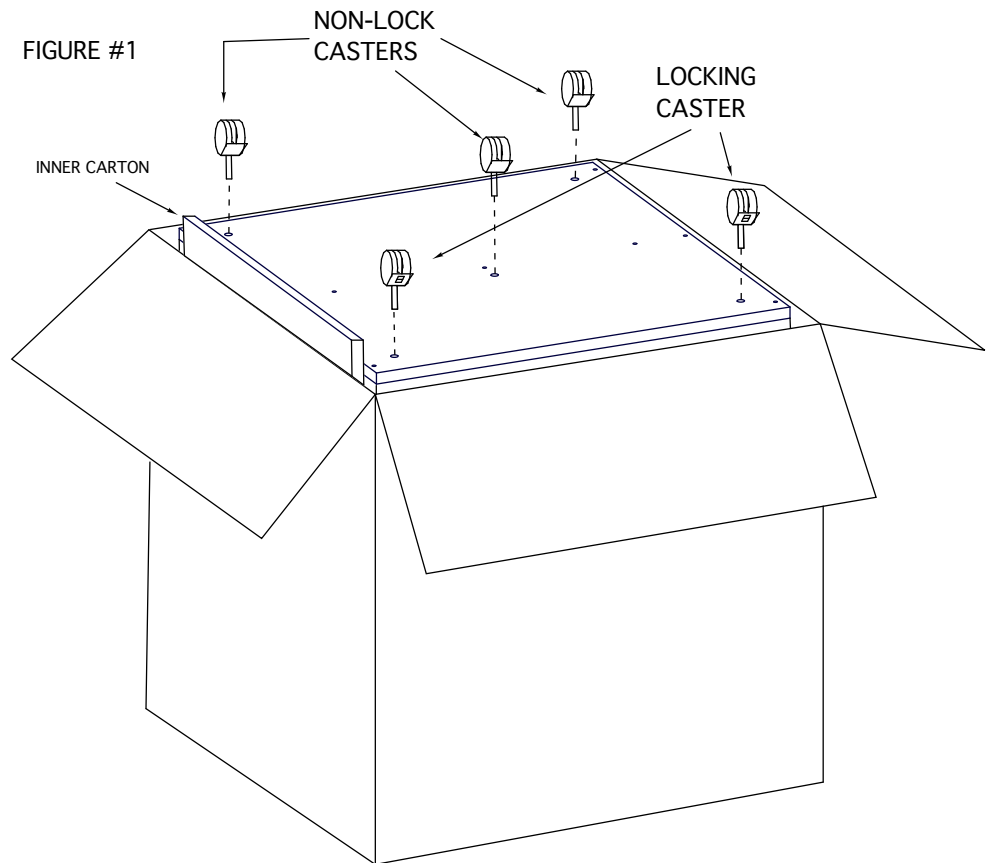

2. REMOVE CONTENTS FROM INNER CARTON AND PLACE ON FLAT WORKING SURFACE. PLACE RISER TOP WITH 5MM HOLES FACING UP. NEXT ATTACH CAM LOCK PINS TO RISER TOP USING PRE-DRILLED HOLES. ALIGN HOLES IN RISER END RAILS WITH CAM LOCK PINS ON RISER TOP AND SECURE BY USING A SCREW DRIVER TO TURN CAM LOCK CLOCKWISE TO TIGHTEN. AS SHOWN IN FIGURE #2 BELOW.

FIGURE #2

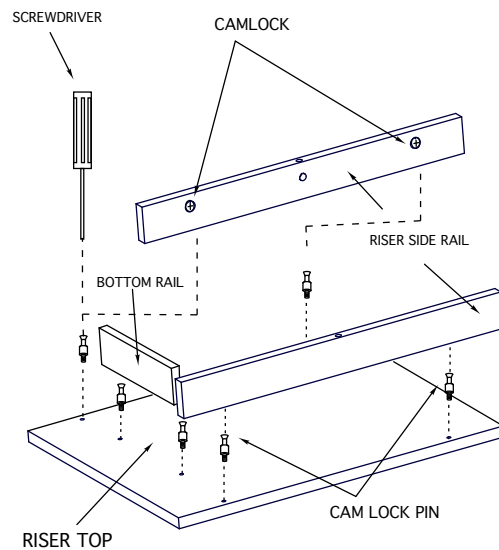

# MODEL: A680 ASSEMBLY INSTRUCTIONS

10/24/2018

3. USING THE PROVIDED 2" CONNECTOR BOLTS, INSERT THROUGH THE BOTTOM OF THE DROP LEAF CONNECTING RISER TO DROPLEAF.

NOTE: RISER CAN BE ATTACHED TO EITHER DROP LEAF.

